

7D Miniature Series PCB Mount

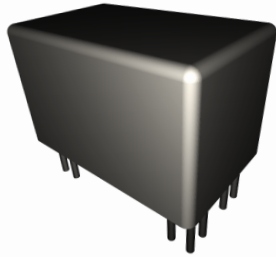

PRODUCT DESCRIPTIONS

The 7D Series is a miniature reed relay, which comes in 1 Form A and 2 Form E configurations. This is the smallest horizontal mounting relay in our product line. Form E is used instead of Form C in order to achieve 300 million times of operations. We mainly provide this series to probe card industries and the instrumentation division in IC manufacturers.



SPECIFICATIONS

7D Miniature Series		7D-1A□2N0		7D-2E□4N1		
Parameters	Units	1 Form A		2 Form E		Test Conditions
Coil Specifications						
Nominal Coil Voltage	VDC	5.0	12.0	5.0	12.0	±10% @ 20°C @ 20°C @ 20°C
Coil Resistance	Ω	160	600	70	450	
Operate Voltage	VDC Max	3.75	8.8	3.75	8.8	
Release Voltage	VDC Min	0.7	1.2	0.7	1.2	
Contact Ratings						
Switching Voltage	Volts	50				Max DC/Peak AC resistance
Switching Current	Amps	0.2				Max DC/Peak AC resistance
Carry Current	Amps	0.75				Max DC/Peak AC resistance (@30°C)
Contact Rating	Watts	5				Max DC/Peak AC resistance
Life Expectancy	x10 ⁶ Cycle	300				@ 1V 10mA
Contact Resistance	mΩ	150				Max initial @ operate voltage
Contact Resistance Stability	mΩ	5.0				Max initial @ operate voltage
Relay Specifications						
Insulation Resistance	Ω Min	10 ¹⁰		10 ¹¹		Between all isolated pins @ 100V 20°C 65%RH
Dielectric Strength	VDC Min	150		150		Between contacts
	VDC Min	200		150		Contacts to shield
	VDC Min	200		150		Contacts/Shield to coil
Operate Time (Including Bounce)	msec Max	0.3		0.5		@ nominal coil voltage
Release Time	msec Max	0.1		0.5		100 Hz square wave Diode suppression
Measurement Reference Conditions				Environmental Ratings		
Temp: 15°C to 35°C Humidity: 25% to 75%RH Atmospheric Pressure: 860 to 1060hpa				Storage temp: -40°C to +85°C Operate temp: -20°C to +60°C Vibration: 20G's to 2000Hz Shock: 50G's		

Ordering Code:

7D-1A□2N0

□=1 (5.0VDC), 2 (12.0VDC)

7D-2E□4N1

□=1 (5.0VDC), 2 (12.0VDC)

Dimensions All Dimensions are inches (mm)

7D-1A □ 2N0

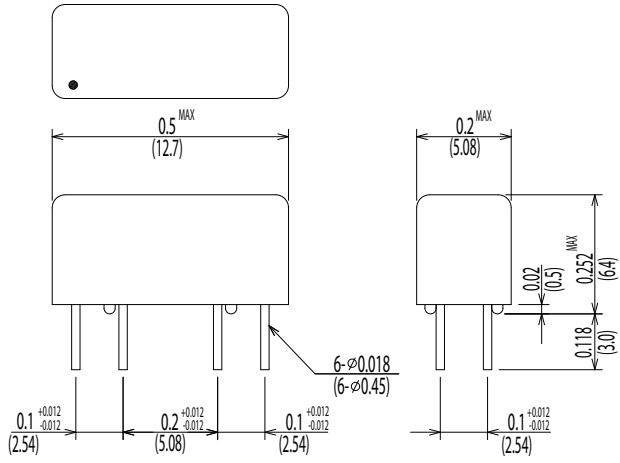

7D-2E □ 4N1

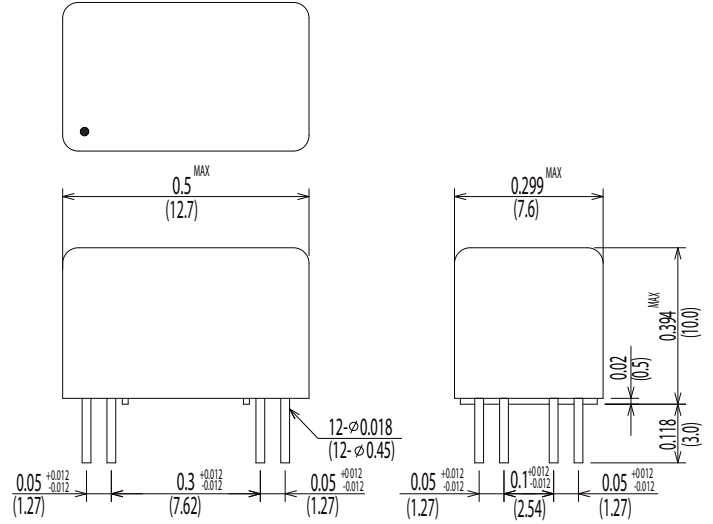

Schematic <Top View>

7D-1A □ 2N0

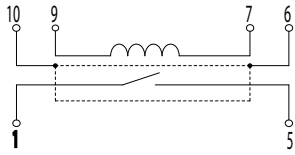

7D-2E □ 4N1

